

Emergency Exit Hardware

Introduction

The Briton 389.N push pad emergency exit device is designed to operate the mortice nightlatch supplied.

Products conforming to EN 179 are only intended for use by personnel who are fully aware of escape routes and have been trained to operate these devices.

Features & Functions

- Push pad operation
- Suitable for single doors and non-rebated double doors
- Variant for metal door applications
- Product designed to satisfy emergency exit applications
- Supplied with dual profile cylinder mortice nightlatch (cylinder not supplied)
- Anti-thrust device, prevents forced latch retraction
- Site reversible for left or right hand
- Suitable for use with outside access device (see datasheet EX_008)



389.N.SE



Certification

UKCA Marked to EN 179 (1121-CPR-UK-ABB7569)

CE Marked to EN 179 (2812-CPR-ABB020)

Certifire Approved (CF5506)

Fire tested to EN 1634-1 for use on fire doors up to 2hr timber / 4hr steel

Environmental Product Declaration in accordance with ISO 14025 and EN 15803

DoP available at www.britondops.co.uk

Emergency Exit Mortice Nightlatch Briton 389.N

Product features	Product references	
	389.N	389M.N
UKCA & CE marked	■	■
Panic exit device to EN 1125		
Emergency exit device to EN 179	■	■
Device type	Push pad	Push pad
Locking points	Single point mortice nightlatch	Single point mortice nightlatch
Suitable for timber or metal doors	Timber	Metal
Suitable for single doors	■	■
Suitable for double door combinations	⊕	⊕
Min. / Max. door width (per leaf)	n/a	n/a
Push bar cut on site	n/a	n/a
Site reversible	■	■
Alarm activation		
Finishes available	SE, SS*,	SE, SS*,
CE Classification	376B1342BA	

- Standard
- Available as an option/variant
- ⊕ Used in combination with Briton 372 vertical bolt device on non rebated double doors.

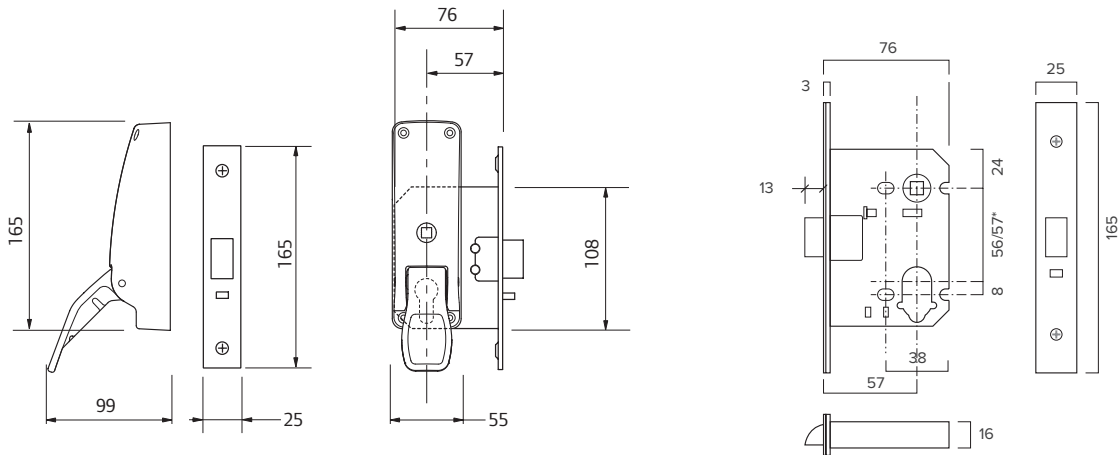

All dimensions are in mm

* Euro profile cylinders 57mm; Oval profile 56mm

Finishes

Available in sprayed silver and PVD plated finishes.



General Maintenance

Exit hardware

All panic hardware installation will be operated by a horizontal “Push bar” or “Touch bar” which runs across the width of the door. The operating bar will be used to operate anything from a single rim latch to multipoint side or top/bottom latches.

Top and bottom latches on Briton 376 panic exit hardware are operated by solid rods which are connected to the operating bar.

MAINTENANCE AND CHECKING FUNCTION

In view of the important role the panic and emergency exit device plays in maintaining the safety and security of your building and its occupants, it is recommended that routine maintenance checks are carried out at intervals of not more than 1 month by the occupier or their approved representative.

Types of maintenance

Much of the routine maintenance recommended consists of a combination of visual and mechanical checks, cleaning and lubrication. Look out for the icons opposite which provide a ‘quick glance’ reminder of the maintenance required.

Visual checks

Primarily making a visual check on the product and surrounding door/frame looking for wear, damage, and general condition.



Functional checks

Consists of checking that the product operates properly without any binding or undue force required. Check that any seals or weatherstripping do not inhibit correct operation of the door.



Check fixings

Fixings need to be checked regularly and tightened when necessary. Check that no projection of fixings prevents the door from swinging freely.



Lubricating

Some products will benefit from periodic lubrication using a light machine oil or as instructed.



Cleaning

Build up of grease, dust and harmful chemicals should be removed to prevent corrosion and maintain the product finish.



Exit Hardware Maintenance

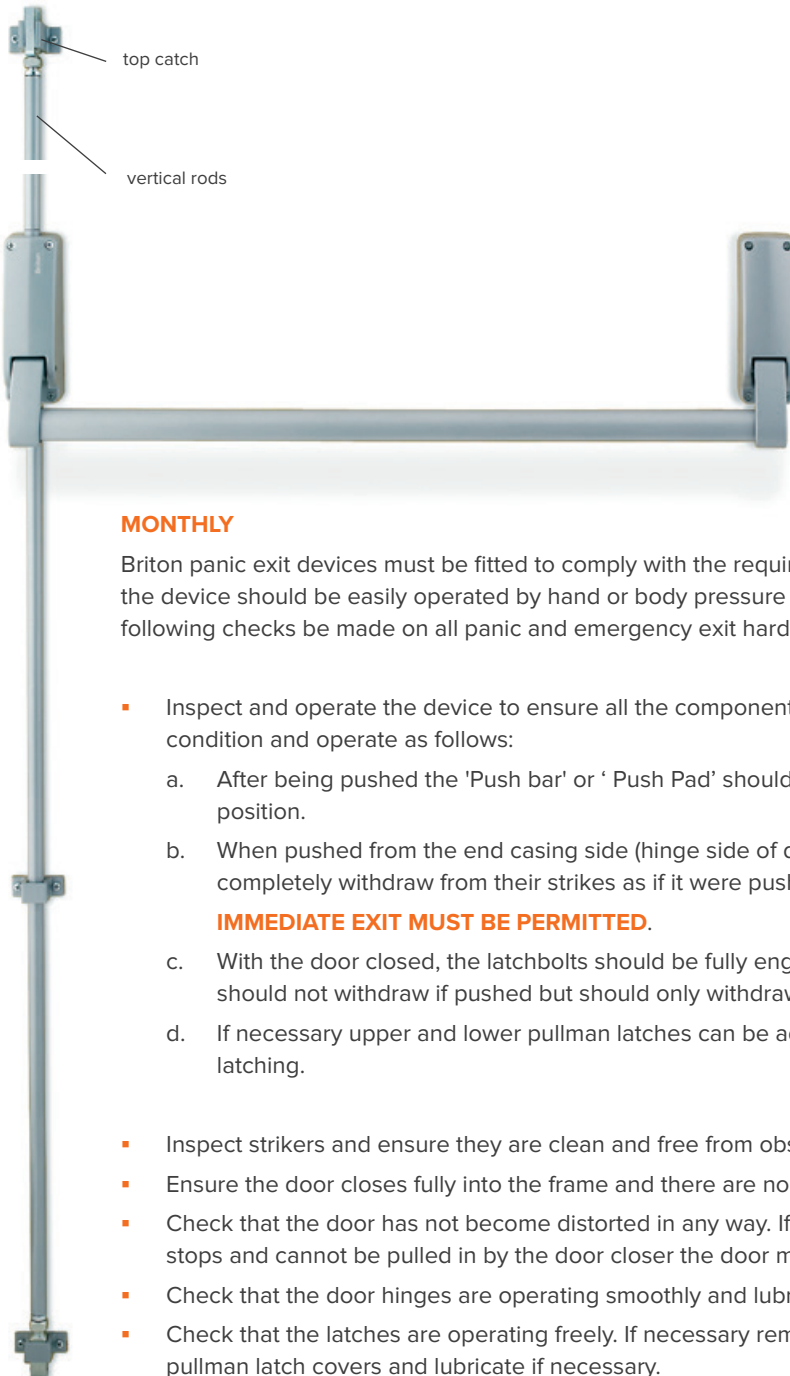

MONTHLY

Briton panic exit devices must be fitted to comply with the requirements of EN 1125 which states that the device should be easily operated by hand or body pressure in a panic situation. We suggest the following checks be made on all panic and emergency exit hardware:

- Inspect and operate the device to ensure all the components are in satisfactory working condition and operate as follows:
 - a. After being pushed the 'Push bar' or 'Push Pad' should return automatically to its initial position.
 - b. When pushed from the end casing side (hinge side of door) the latchbolt(s) should completely withdraw from their strikers as if it were pushed from the main casing side.
IMMEDIATE EXIT MUST BE PERMITTED.
 - c. With the door closed, the latchbolts should be fully engaged into their strikers. They should not withdraw if pushed but should only withdraw if operated by the 'Push bar'.
 - d. If necessary upper and lower pullman latches can be adjusted to ensure the accuracy of latching.
- Inspect strikers and ensure they are clean and free from obstruction.
- Ensure the door closes fully into the frame and there are no obstructions.
- Check that the door has not become distorted in any way. If the door does not meet the frame stops and cannot be pulled in by the door closer the door may need to be replaced.
- Check that the door hinges are operating smoothly and lubricate if necessary.
- Check that the latches are operating freely. If necessary remove the end box covers and/or pullman latch covers and lubricate if necessary.
- Check that all fixings are tight.



If problems persist and for some reason the panic device does not operate properly, consult your approved supplier or contact the Allegion Customer Care Team on 0330 8080 617